

TRUFLO LSS & LS SERIES INSTALATION MANUAL

PADDLE WHEEL FLOW METER

- Up to 24" Pipe Size
- Zirconium Ceramic Rotor + Bearings
- Accuracy $\pm 0.75\%$ of FS



SERIES : LSS & LS



LSS
SERIES



LS
SERIES

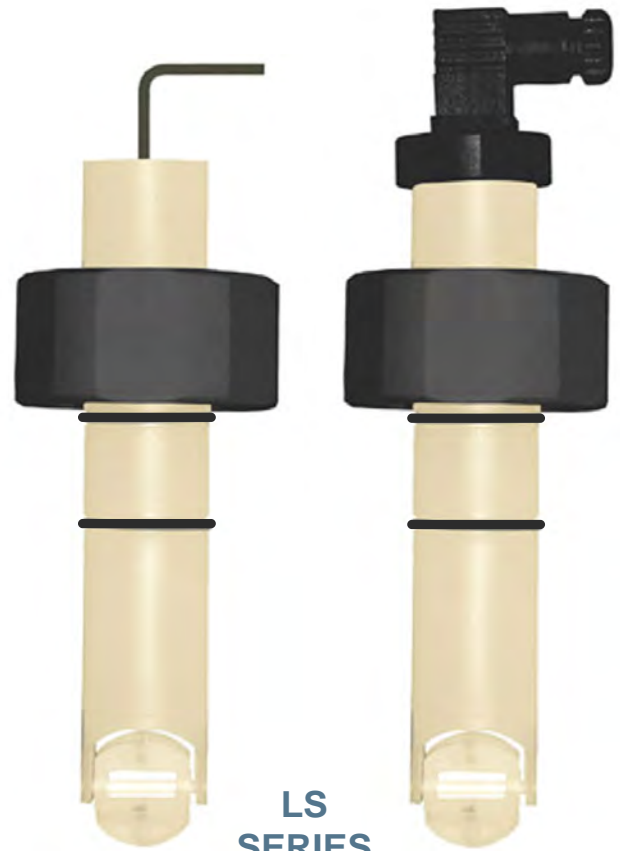

⚠ Press at the Same Time during Programming to Return to Home Screen

Read the user's manual carefully before starting to use the unit or Programming
Manufacturer reserves the right to implement changes without prior notice

Quick Start LSS & LS Series Proper Installation Instructions

LSS Series

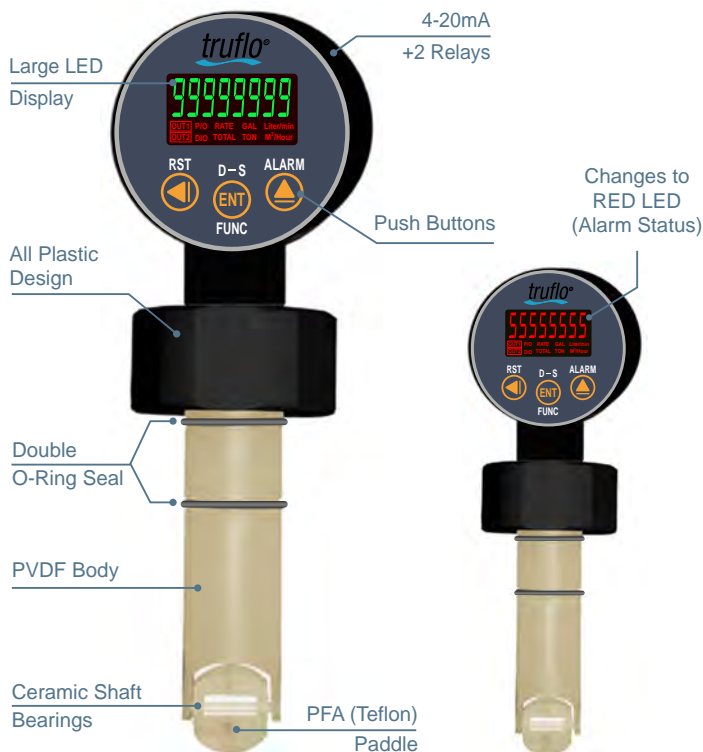

LS & LSS Series Paddlewheel Flow Sensors are Very Accurate, Heavy Duty Sensors that offer Exceptional Value. Truflo Sensors Measure liquid Flow Rates in Full Pipes.

- The wetted materials are PFA, Ceramic and PP, PVDF making this model highly versatile and chemically compatible with many liquid process solutions.
- Sensors can be installed (½ to 24 in.) pipes using Truflo extensive line of custom fittings.
- These fittings, include Tees, Saddles, and Weldolets, and Align and Position the sensor to the Proper Insertion depth Providing Accurate Flow Measurement.

⚠ Remember to Lubricate O-Rings (Grease Supplied) Use an Alternating Twisting Motion when Carefully inserting Sensor into Fitting (Grease Included). Remember this is an Instrument + Handle With Care

LS Series

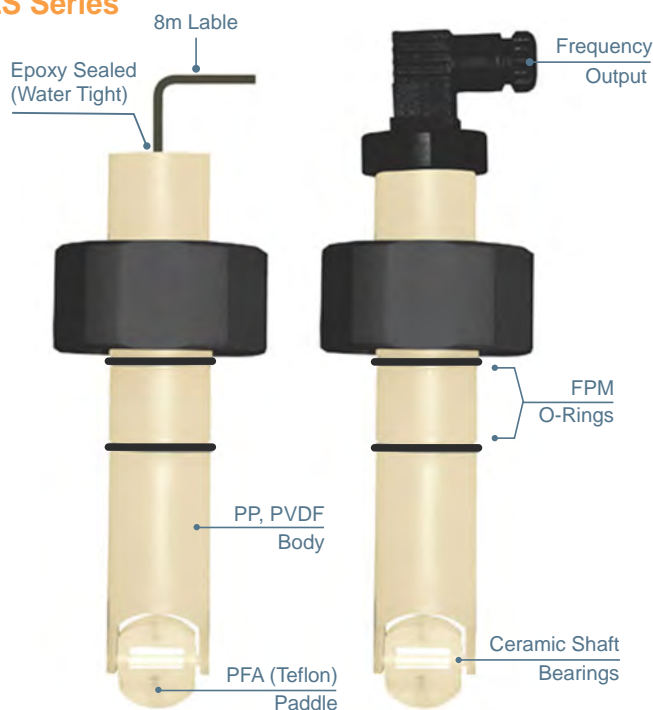

Advantages LSS & LS Models

- Flow Rate Range 0.3 to 10 m/s (1 to 33.3 ft/s)
- Installs into pipe sizes (½ to 24 in.)
- Wide Turndown Ratio of 33:1
- Industry's Most Accurate (0.15%) Paddle Wheel Flow Meter
- Rugged Industrial Design
- Easy to Replace Rotor
- Industry's Most Chemical Resistant
- Materials PP-PVDF-PFA-Ceramic

⚠ Important Proper Installation Method

Ensure Silicon Grease (Supplied) is Applied Prior to Insertion

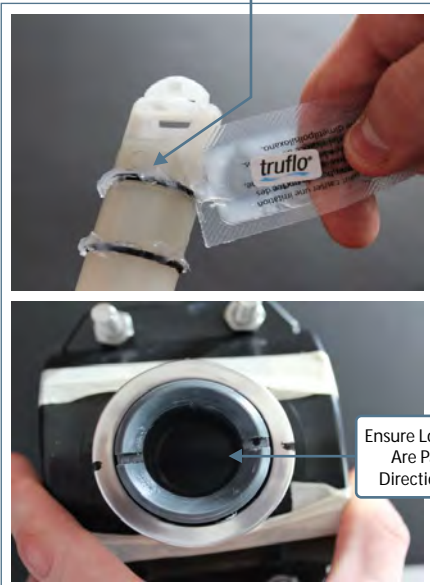

Ensure Location Tabs Are Parallel to Direction of Flow

Correct Sensor Positioning

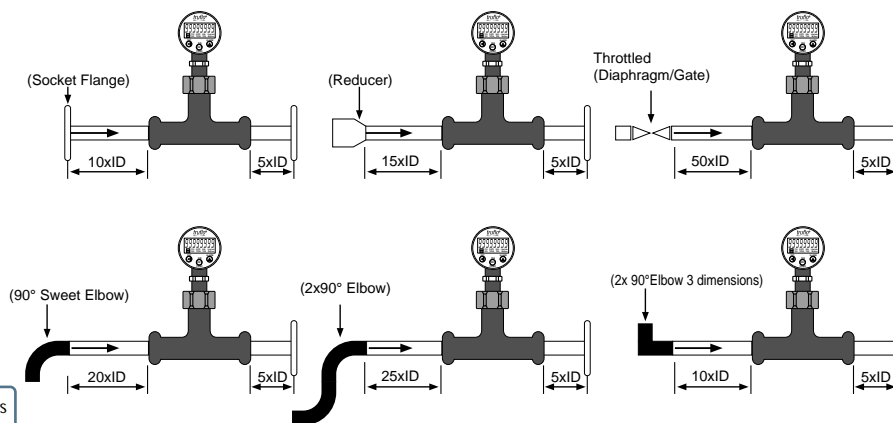

Always Maximize the Distance Between Flow Meter and the Pump / Valve or Fitting.

Sensor Mounting Position

Horizontal Pipe Runs :

- ➔ Mount sensor in the upright (0°) position for best performance.
- ➔ Mount at a Maximum of 45° when Air Bubbles are present.
- ➔ **Do not** mount on the bottom of the pipe when Sediments is present.

Vertical Pipe Runs :

- ➔ Mount sensor in any orientation.
- ➔ Upward Vertical flow is Strongly Recommended to Ensure Full Pipe.

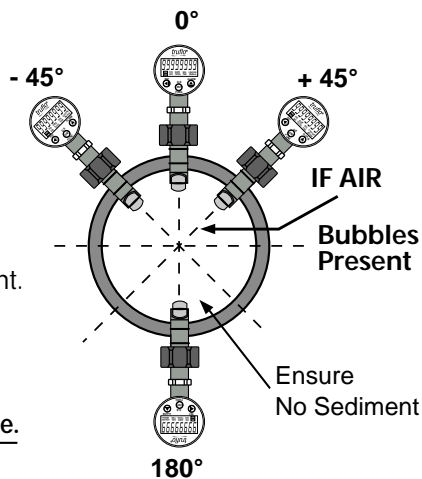

Maximum Operating Pressure/Temperature

- PP Body : (180psi @ 68°F) (25psi @ 176°F)
- PVDF Body : 200psi @ (-20 to 27°C) (-4 to 81 F)

Temperature (°F) 36psi @ 80°C (188°F)

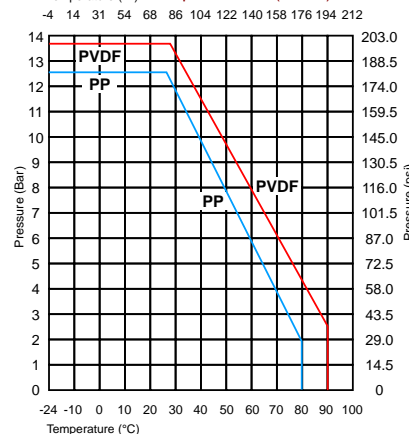

⚠ Important Proper Installation Method

LSS & LS Sensor Installation



Lubricate O-rings with a Viscous Lubricant (grease) compatible with the system.
Very Important (Grease Enclosed)

- ➔ Using an **Alternating/Twisting Motion**, Carefully lower the sensor into the fitting. Do Not Force
- ➔ Engage one thread of the sensor cap then turn the sensor until the alignment tab is seated in the fitting notch (Fig-1) Ensure Tab is Parallel to Flow Direction.



Ensure Tab / Notch are Parallel to Flow Direction Fig-2



Hand Tighten the Sensor Cap. **DO NOT** use any tools on the sensor cap or the cap threads or fitting threads may be damaged, see Fig-1

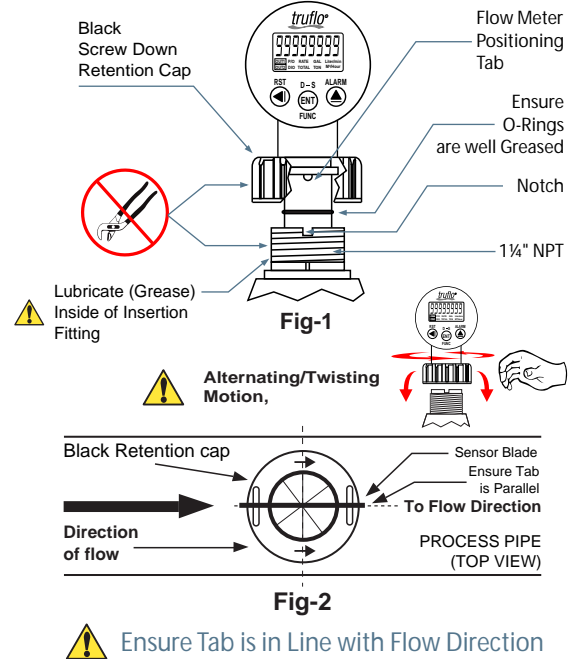

Sensor Wiring (DC Power Only)

- Use conductor shielded cable 24V DC (20-26 AWG).
- Cable shield must be maintained through cable splice.

LS Sensor Wiring Diagram 5-24VDC

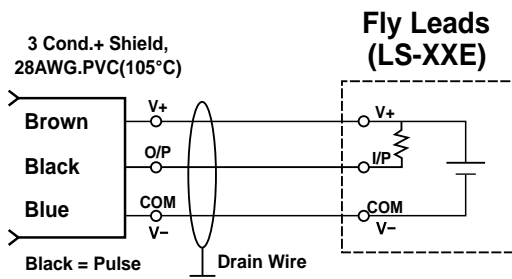

DIN Quick Connector

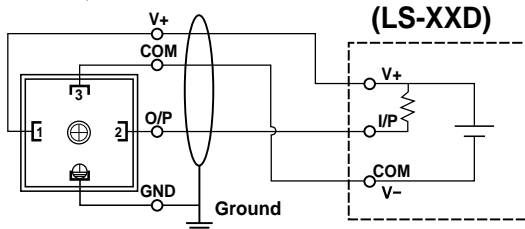

LSS Series 14-28VDC

- **Analog (4-20mA)/RS-485/Pulse Output Type (Depending on Type)**

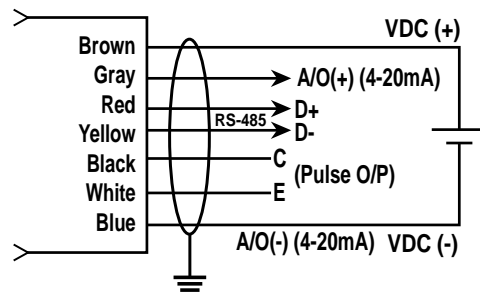

LSS Series

- **Relay Outputs**

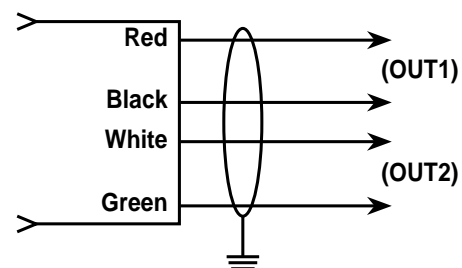

TRUFLO LSS PROGRAMMING INSTRUCTION MANUAL

FRONT PANEL & KEY FUNCTIONS

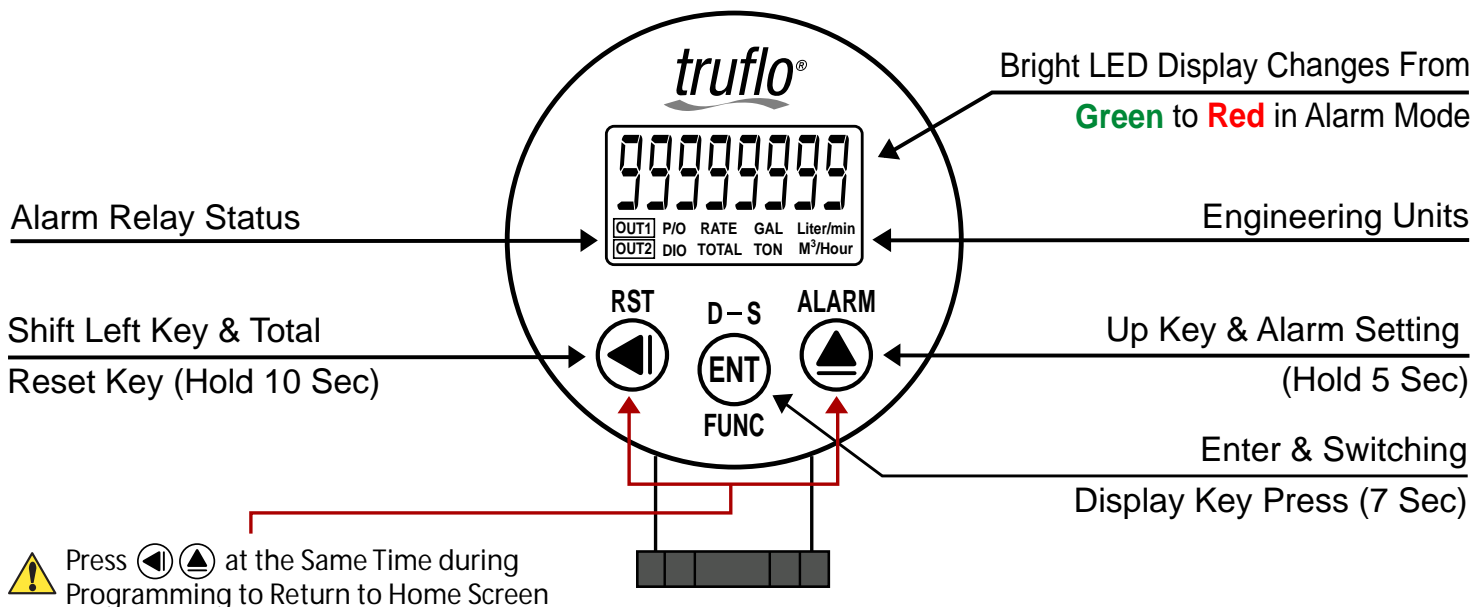

LSS SERIES

Key Name	Symbol	Descriptions
Enter Key & Save Key		<ol style="list-style-type: none"> 1. In the Measuring Status, Press this Key for 5 sec to enter Programming. 2. In the Measuring Status, Press this Key to Switch the Rate & Total Value. 3. In the Measuring Status, Press this Key to Save the Value & Go to Next Programming Screen.
Shift Key & Total Reset Key		<ol style="list-style-type: none"> 1. Press this Key for 10 sec to Reset the Total Value. 2. Pressing this Key will Move the Cursor Left.
UP Key & Alarm Setting Key		<ol style="list-style-type: none"> 1. Press this Key for 5 Sec to Enter to Alarm Programming Screen. 2. Pressing this Key will Increase the Digits.

1. To modify the Settings, please press and press to save the Settings after the modification is made.

2. Remember the New Passcode If Changes Are Made!

3. In any Screen, press , Together During programming Stage to return Immediately to Home screen (Note : AFTER 2 mins the Display will Return to Home Screen).

GENERAL MODE OPERATING PROCEDURES

Follow Hand For Programming

Alarm Setpoint

Block Charts

Power On

Press (5 Sec) → 10000

Press (1 Sec) → AL 1.5

Press (1 Sec) → AL 2.5

Display	Descriptions	Default
Measuring Status	Current Value On Display	0
Alarm 1 Setpoint (AL1)	To Move Cursor → To Increase or Decrease Press to Modify Alarm 1 Setpoint. (Flow Rate) Display Changes From Green to Red In Alarm Start	00000
Alarm 2 Setpoint (AL2)	To Move Cursor → To Increase or Decrease Press to Modify Alarm 2 Setpoint. (Flow Rate) Display Changes From Green to Red. In Alarm State	00000

Press at the Same Time during Programming to Return to Home Screen.

FLOW ALARM MODE

When AL=HI, DELAY= 0 :

Current Value > Programmed Value (AL) + Hysteresis (HYS) → (Relay On)
 Current Value < Programmed Value (AL) – Hysteresis (HYS) → (Relay Off)

When AL=HI, DELAY= 1 – 99 sec.:

Current Value > Programmed Value (AL) + Hysteresis (HYS) + Delay Time (DEL) → (Relay On)
 Current Value < Programmed Value (AL) – Hysteresis (HYS) → (Relay Off)

When AL=HI, DELAY= -1 – 99 sec.:

Current Value > Programmed Value (AL) + Hysteresis (HYS) → (Relay On + (DEL) and then off)
 Current Value < Programmed Value (AL) – Hysteresis (HYS) → (Relay Returns to Normal State After the Procedure)

When AL=LO, DELAY= 0 :

Current Value > Programmed Value (AL) + Hysteresis (HYS) → (Relay Off)
 Current Value < Programmed Value (AL) – Hysteresis (HYS) → (Relay On)

When AL=LO, DELAY = 1 – 99 sec.:

Current Value > Programmed Value (AL) + Hysteresis (HYS) → (Relay Off)
 Current Value < Programmed Value (AL) – Hysteresis (HYS) + Delay Time (DEL) → (Relay On)

PROGRAMMING MODE OPERATING PROCEDURES

Follow Hand For Programming

Display	Descriptions	Default
Measuring Status	Current Flow Value. (Press 5 Sec)	
Pass Code (P.Cod)	Press to enter Passcode.	00000
	If Passcode is correct mode the Flow Meter will enter into Programming Status. If Passcode is incorrect the Display will to Return to Measuring Status.	
	Press Enter Again	

Remark

- There are Four (4) Different Programming Windows (1) "System Programming Group (SYS)" (2) "Alarm Programming Group (roP)" (3) "Analog 4-20mA Output Setting (AoP)" (4) "RS485 (Optional) Programming (doP)".
- Press to select each Section Screen Press to enter Programming page for modifying the parameters.

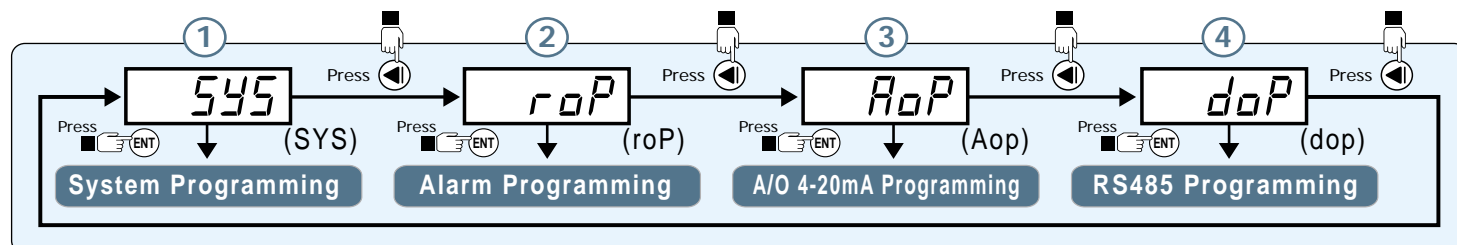

System Programming Steps

Follow Hand For Programming

Display	Descriptions	Default
Flow Unit Setting (Unit)	Press to modify the Unit of measurement (Liter, Gal, Ton., m ³)	LTR
Sampling Time Base (idC-t)	Press to Change sampling time (0.5, 1.0, 2.5, 5.0 sec).	10
Decimal Point of Rate Setting (dPr)	Press to select decimal point (0,1,2,3,4) (0 STD).	00000
Decimal Point of Total Setting (dPt)	Press to select total decimal point (0,1,2,3,4) (0 STD).	00000
Time Parameter Setting (t-unit)	Press to modify time parameter (sec/min/hour) Minutes (Recommended)	SEC
K Factor Setting (K-F)	Press to modify K Factor (0.1 - 999.999 Section See Fittings Section Page 8)	10000
Passcode Setting (CodE)	Press to modify passcode (0-19999). PS: Please don't forget the new passcode after Change.	00000
Key Lock Setting (LoCK)	Press to lock the keys, using key lock function allows only viewing of the programs, but any change any of the values will be blocked. No (unlock), YES ("ENT" unlock).	no

⚠ Press ◀▶ at the Same Time during Programming to Return to Home Screen

Programming Alarm SET POINTS

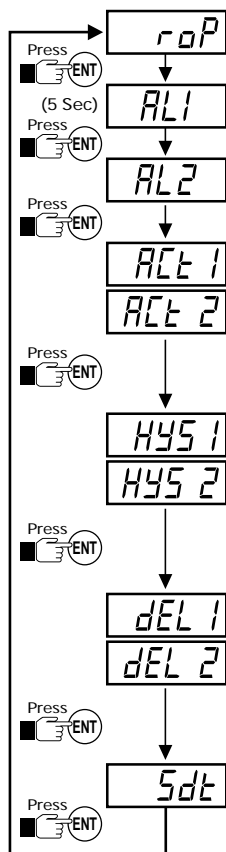

Display		Descriptions	Default
Alarm Setting Page (roP)		The following steps are only available for alarm output.	
Alarm 1 Selection Setting (AL 1)		Press ▶ to select alarm 1 (Flow Rate or Total).	RATE
Alarm 2 Selection Setting (AL 2)		Press ▶ to select alarm 2 (Flow Rate or Total)	RATE
Alarm 1 (ACT1)	Alarm Action Setting	Press ▶ to Change Alarm Set Point Value that is \geq (Hi) or $<$ (Lo) for alarm Relay action. Hi = Above Current Flow Lo = Below Current Flow	HI
Alarm 2 (ACT2)			
Hysteresis 1 (HYS1)	Alarm Hysteresis Setting	Press ◀▶ to modify the Hysteresis value, when Flow Rate runs below or above display value (depends on alarm action). Alarm setpoint \pm this value (0-999) will turn off the alarm. Note : If AL1.5 or AL2.5 are set to Alarm based on Total (see above) then the Hysteresis will be Disabled	00000
Hysteresis 2 (HYS2)			
Delay Time 1 (dEL1)	Alarm Run Delay Setting	Press ◀▶ to modify the value, Based on Value Entered the Alarm will activate only when the Display Value is Reached and the time is passed Initial Start - Up - (Prevents False Alarms)	00000
Delay Time 2 (dEL2)	Alarm Run Delay Setting	Press ◀▶ to modify the value, when the display value reach the alarm value Set the delay (sec) before alarm Activates (0-99 sec) for alarm action. Initial Start - Up - (Prevents False Alarms)	00000
Alarm Start Band Time Setting (Sdt)		Press ◀▶ to modify the value (0-99 sec), if the display value hits alarm start band value; the alarm will be active (sec). Initial Start - Up, Filter Change Out	00000

⚠ Press ◀▶ at the Same Time during Programming to Return to Home Screen

Programming 4-20mA Analog Output (A/O)

For Calibration Purposes Only

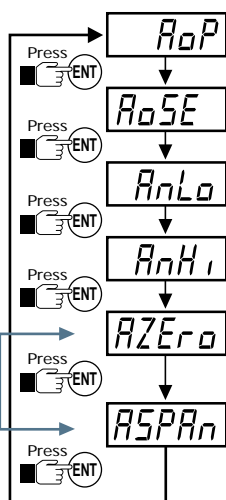

Display		Descriptions	Default
A/O Programming (AoP) 4-20mA		The following steps are only available for analog output.	
A/O Selection Setting (Ao.SEL)		Press ▶ to select 4-20mA output for Flow Rate or Flow Total.	RATE
A/O Low Scale Setting (AnLo)		Press ◀▶ to adjust A/O low scale to correspond to the display value (programmable). Ex: A/O is 4-20mA the display is 0 to output 4mA, this value must be set for 0	00000
A/O High Scale Setting (AnHi)		Press ◀▶ to adjust A/O hi scale to correspond to the display value (programmable). Ex: A/O is 4-20mA, the display is 90.0 to output 20mA, this value must be set for 90.0	99999
A/O Zero Adjustment (AZero)		Press ▶ to select adjusting For Valves Above Flow Rate, press ▶ to modify the A/O zero. PS: Use this function to adjust the real A/O zero. i.e. If you wish to have 0mA read other than 0 i.e. 10 GPM	00000
A/O Span Adjustment (ASPAn)		Press ◀ to select adjusting flow rate, press ◀ to modify the A/O span. PS: To use this function to adjust the real A/O span. i.e. Flow Rate 20mA =150 GPM. When you wish to Set a pre-determined Max Flow Value	00000

Note : All Sensors are Factory Calibrated - Calibration Not Required

RS485 Setting Procedures (Optional)

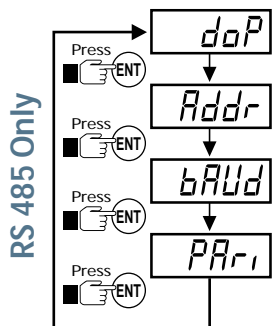

Display	Descriptions	Default
doP	RS485 Setting Page (doP) The following steps are only available for RS-485. (Special Order)	
Addr	Address Setting (Addr) Press ◀ ▶ to modify address (0~255).	00000
bAUd	Baud Rate Setting (bAUd) Press ▲ to select baud rate (19200/9600/4800/2400).	19200
PAri	Parity Setting (PAri) Press ▲ to select parity (n.8.2/n.8.1/even/odd).	882

Self-Diagnosis Error Code

Appendix	Error Mark Description	Error Mark	Analyze & Description
1	Input over error detect	10FL	Input signal over range (120%)
2	Input under error detect	-10FL	Input signal under range (-20%)
3	Display over error detect	doFL	Display over range (99999)
4	Display under error detect	-doFL	Display under range (-19999)
5	AID Converter error detect	AdEr	1. Input signal over range (180%) 2. Inside circuit damage Please movmg input signal if still display ADER , please contact us
5	EEPROM error detect	E-00	1. Internal flash memory read/write 2. Flash memory write about 100 thousand times (guarantee 10 years) Please power reset, if still display E-00, doing following step: 1. E-00 & No a1 ternate display for inquire reset FLASH memory 2. Decide Yes with ◀ ▶ key, press ENT key return normal display 3. Flash memory was reset, Please follow step 1~12 set again
		no	
		YES	

Pressure		Units		Conversion		Table	
bar	Kg / cm2	KPa	MPa	PSI	rnmHg	inHg	
1	1.01972	100	0.1	14.5036	750.062	29.53	

SPD3 Modbus RTU Mode Protocol Address Map

Aia formai 16/32Bii ,sign bit 8000~7FFF(-32768~32767) / 80000000~7FFFFFFF (-2147483648~2147483647)

Address	Name	Description	Accep
0000	RANGE	Pressure range, range 0000~0003 (0~3) 0: -1~2 bar, 1: -1~10 bar, 2: -1~ 50 bar, 3:0 ~ 250 bar	R
0001	UNIT	Display unit, range 0000~0006(0~6) 0 : bar, 1: Kg/cm, 2 : Kpa, 3 : Mpa, 4 : mmHg, 5 : PST, 6 : inHg	R/W
0002	DP	DP, range 0000~0004(0~4) 0:10 ⁰ , 1:10 ⁻¹ , 2:10 ⁻² , 3:10 ⁻³ , 4:10 ⁻⁴	R/W
0003	OUT T	OUT-T, range 0000~0002(0~2) 0:H, 1:C, 2:D	R/W
0004	ADDR	ADDR, range 0000~00FF(0~255)	R/W
0005	BAUD	BAUD, range 0000~0003(0-3) 0:19200, 1:9600, 2:4800, 3:2400	R/W
0006	PART	PART, range 0000~0003(0~3) 0:N. 8.2., 1:N.8.1., 2: EVEN(E81), 3: ODD(O81)	R/W
0007	LI:X:K	LOCK, range 000~001(0~1) 0:NO 1:YES	R/W
0008	LCUT	LCUT, range 0000~03E8(0~999)	R/W
0009	IDCT	IDC_T, range 0001~0063(1~99)	R/W
000A	HYS	HYS, range 0000~03E7(0~999)	R/W
000B	AZERO	AEZRO, range 0000~4E20 (0~20000)	R/W
000C	ASPANT	ASPAN, range 4E20~FFFF (20000~65535)	R/W
000D	ere	CJC, range FC19~03E7 (-999~999), if temperaiure is 25.0°C value is 250, OOFA (HEX)	R/W
000E	ANLO	ANLO, range FFFFB1E1~0001869F (-19999~99999)	R/W
0010	ANHT	ANHT, range FFFFB1E1~0001869F (-19999~99999)	R/W
0012	CODE	CODE, range 00000000~0001869F (0~99999)	R/W
0014	P-1	P-1, range FFFFB1E1~ 0001869F (-19999 99999)	R/W
0016	P-2	P-2, range FFFFB1E1~ 0001869F (-1999999999)	R/W
OOIC	DISPLAY	DISPLAY, range FFFFB1E1~ 0001869F(-19999~99999)	R

CPVC TEE FITTING (SCH80)

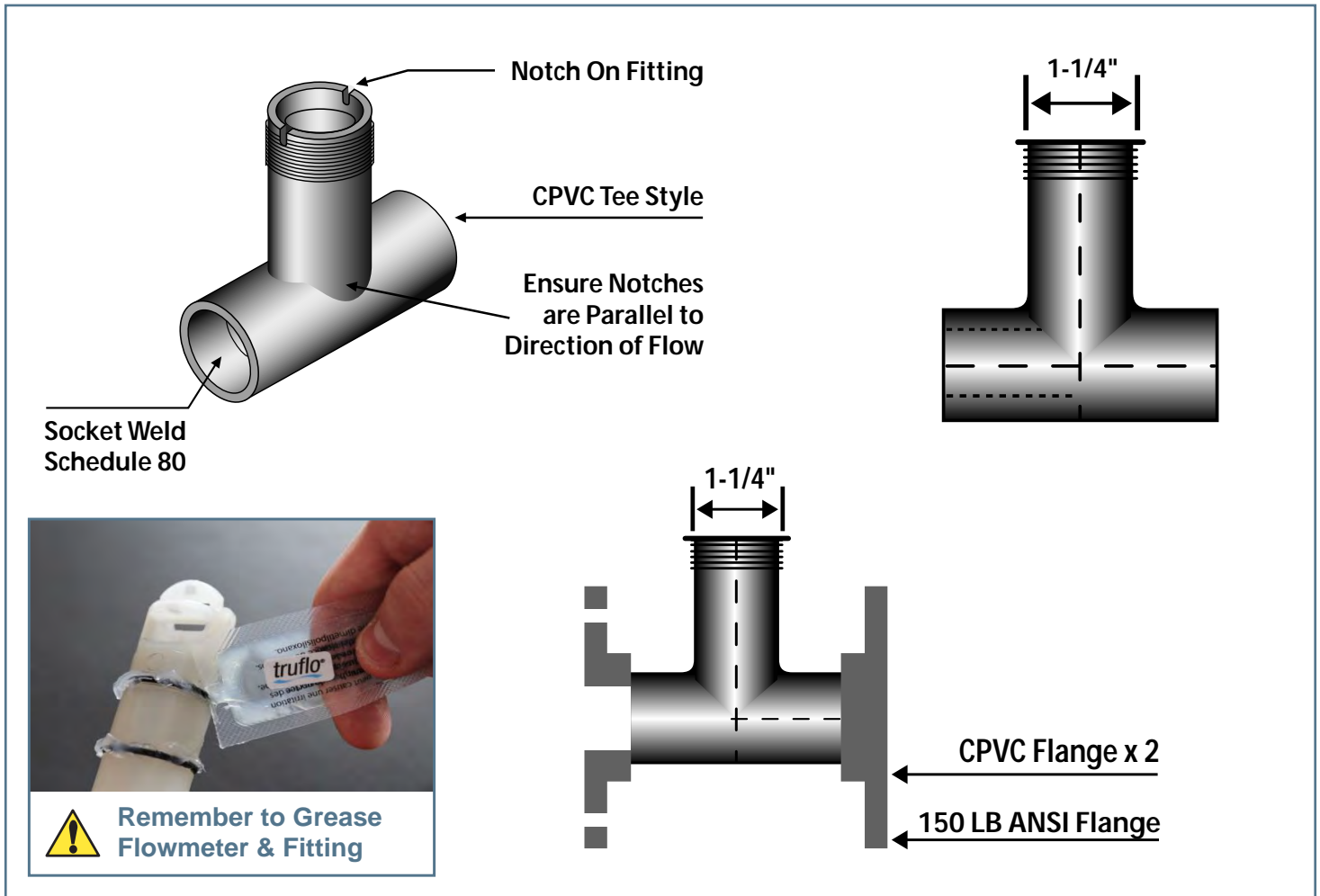

K-Factor - PULSE /LITER

Tee fitting (Unit:inch)			K-Factor	Sensor Length	Tee fitting (Unit:inch)			K-Factor	Sensor Length
Size	DN	Id	CPVC (SCH80)		Size	DN	Id	CPVC (SCH80)	
1/2"	15	0.55	213.40	T	2"	50	1.90	28.71	T
3/4"	20	0.74	113.24	T	2-1/2"	65	2.30	19.60	T
1"	25	0.96	88.08	T	3"	80	2.90	11.89	T
1-1/4"	32	1.30	49.63	T	4"	100	3.83	6.23	T
1-1/2"	40	1.50	41.27	T	6"	150	3.80	2.60	T1

Note : CPVC = PVC (for ISO SDR21 pipes and ASTM SCH80 PVC, CPVC Plastic Pipe)

*DIVIDE K factor by 3.8 to change to Pulse/Gallon

(Max Fluid Velocity should NOT EXCEED 8 ft/sec)

K FACTOR TABLES

CPVC+PP CLAMP SADDLES (SCH80)

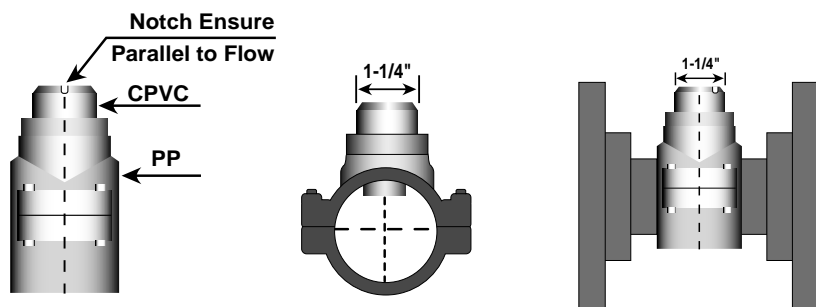

Clamp Saddles (Unit:In)			K-Factor (Pulse/Liter)	Sensor Length
Size	DN	Id	CPVC (SCH80)	
2"	50	1.9	29.00	T
2-1/2"	65	2.3	19.76	T
3"	80	2.9	12.00	T
4"	100	3.8	6.276	T
6"	150	5.7	2.596	T1

Note : CPVC=PVC (for ISO SDR21 Pipe and ASTM SCH80 PVC, CPVC Plastic Pipe)

*CHANGE TO PULSE/GPM DIVIDE K FACTOR BY 3.8

CPVC SOCKET WELD-ON ADAPTERS

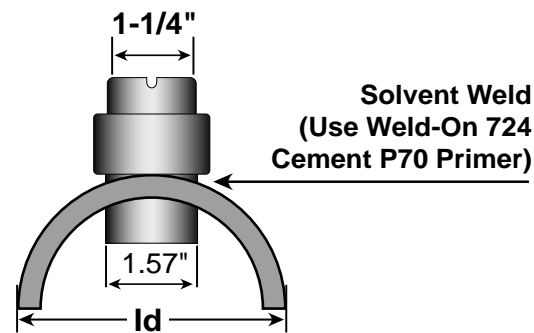
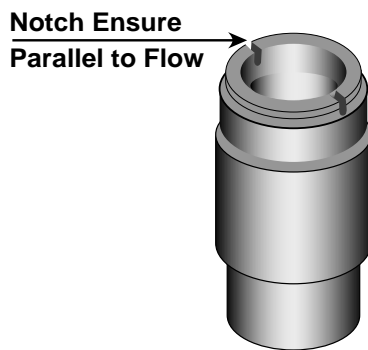
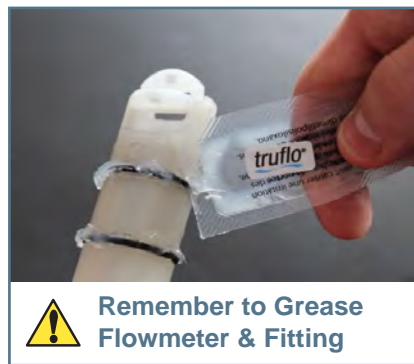

Glue-On Adapters(Unit:inch)			K-Factor (Pulse/GAL)	Sensor Length
Size	DN	Id	CPVC (SCH80)	
2"	50	1.9	29.00	T
2-1/2"	65	2.3	14.76	T
3"	80	2.9	12.00	T
4"	100	3.8	6.27	T
6"	150	5.7	2.60	T1
8"	200	7.0	1.42	T1

Glue-On Adapters(Unit:inch)			K-Factor (Pulse/GAL)	Sensor Length
Size	DN	Id	CPVC (SCH80)	
10"	250	9.5	0.90	T1
12"	300	11.3	0.64	T1
14"	350	12.4	0.53	T1
16"	400	15.1	0.40	T1
20"	500	19.0	0.77	T1
24"	600	21.0	0.18	T1

* DIVIDE K factor by 3.8 to change to Pulse/Gallon

- GO WITH FLOW
- FITTING FOR LS & LSS SERIES PADDLE WHEEL FLOW METERS

**TEE FITTING (SCH 80)
MODEL CT -**

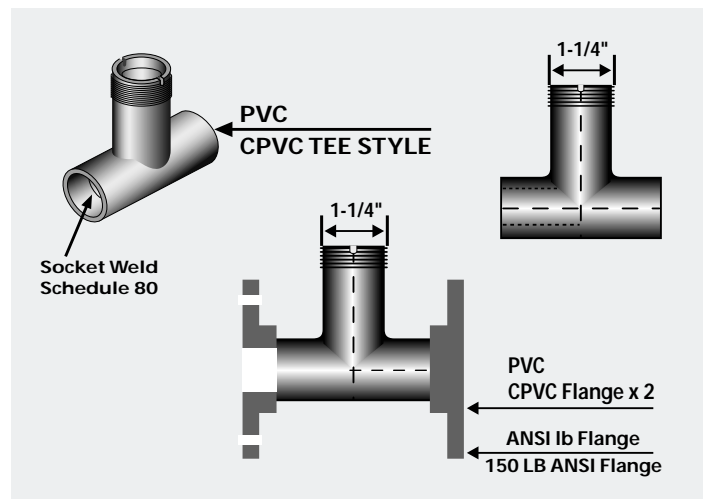

PVC / CPVC Tee fitting for ASTM SCH80 Pipes	40	4"	T
---	----	----	---

**CPVC + PP CLAMP SADDLES (SCH80)
MODE L : SA -**

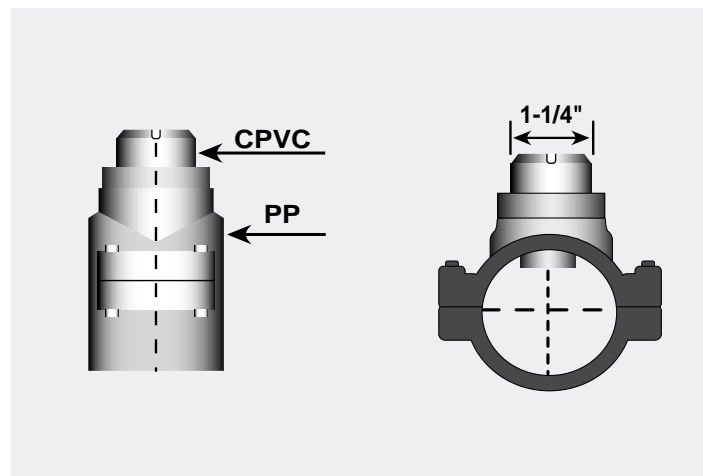

- **Note 1** : SUS304 Bolt and Nut for PP Clamp Saddles
- **Note 2** : LCLS - A or C XX (Drilling hole = 40mm)

**CPVC GLUE-ON ADAPTERS
MODEL : PLGS -**

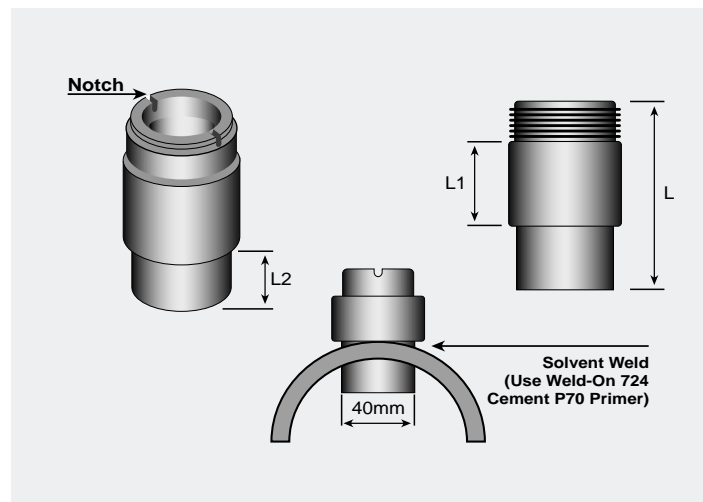

□ □

NO	PIPE Size (DN)	Sensor Length
GT	0.5" - 4" (15-100)	T
T1	6" - 24" (150-600)	T1

CPVC SOLVENT CEMENT - WELDON 724 + P70 Primer

LS & LSS SERIES SADDLES DIMMENSIONS

129		REINFORCED PP CLAMP SADDLE - 4 BOLTS SS316 & VITON			
STD Code	Ø Pipe - C	Weight (g)	A	B	D
03144	2" (50) - 1 ¼"	306	70	99	23
03077	3" (90) - 1 ¼"	380	87	129	23
03082	4" (110) - 1 ¼"	503	104	155	23

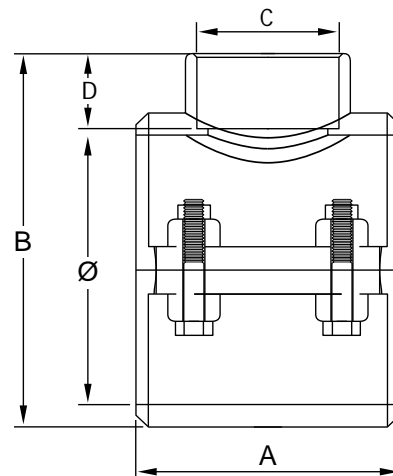

128		REINFORCED PP CLAMP SADDLE - 6 BOLTS SS316 & VITON			
STD Code	Ø Pipe - C	Weight (g)	A	B	D
03096	6" (160) - 1 ¼"	1142	136	210	23
03100	8" (200) - 1 ¼"	1982	173	244	23

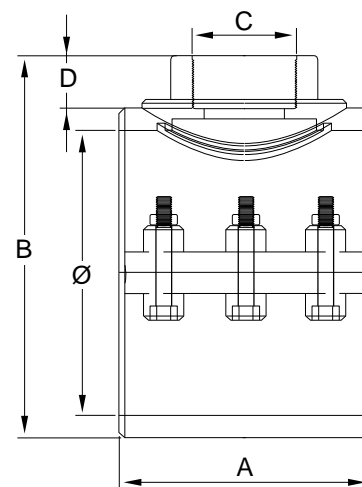

137		PP HINGED SLEEVE - 3 BOLTS SS316						
WEIGHT (g)	STD Code	Ø Pipe	Ø Outlet	A	B	C	D	E
03144	05203	10" (225)	1 ¼"	225	225	283	9	26
03077	05066	12" (250)	1 ¼"	250	239	308	9	26
03082	05213	14" (315)	1 ¼"	315	250	370	9	26
03082	05484	16" (400)	1 ¼"	400	282	474	9	26

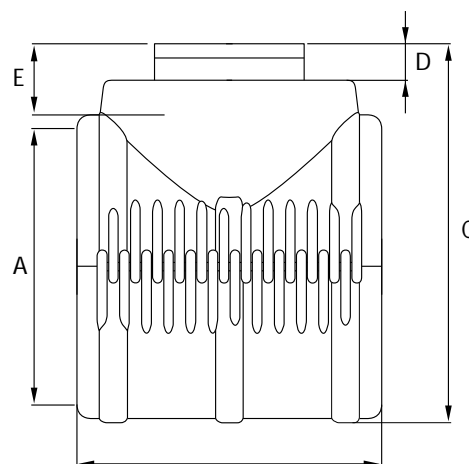

LSS & LS SERIES

PADDLE WHEEL FLOW METER



LSS

	Sensor body	Sensor Length	Alarm Output	Analog Output	RS-485 Output	Pulse Output	O-rings	Cable length
3	PP	0 2.70 in (T)	2 Two Relay	3 4-20mA	N None	N None	F FKM	8 8M Standard
6	PVDF	1 3.88 in (T1)	2 Two Relay	3 4-20mA	Y RS-485	N None	E EPDM	C Customes

• T (Pipe size 0.5" to 4")
 • T1(Pipe size 6"to 24")

• Relay Contact
 • (DC 30V-7A)

LS

	Sensor Body Material	Sensor Length-Pipe Diameter	Electrical Connection/Protection Class	O-rings
3	PP Body	0 (1/2"-4")	D DIN mini-connection 43650-A/IP65	F FKM(Viton)
5	PVDF	1 (6"-24)	E Electrical cable (customer) -IP68	E EPDM

LSS DIMENSION (unit : inch)

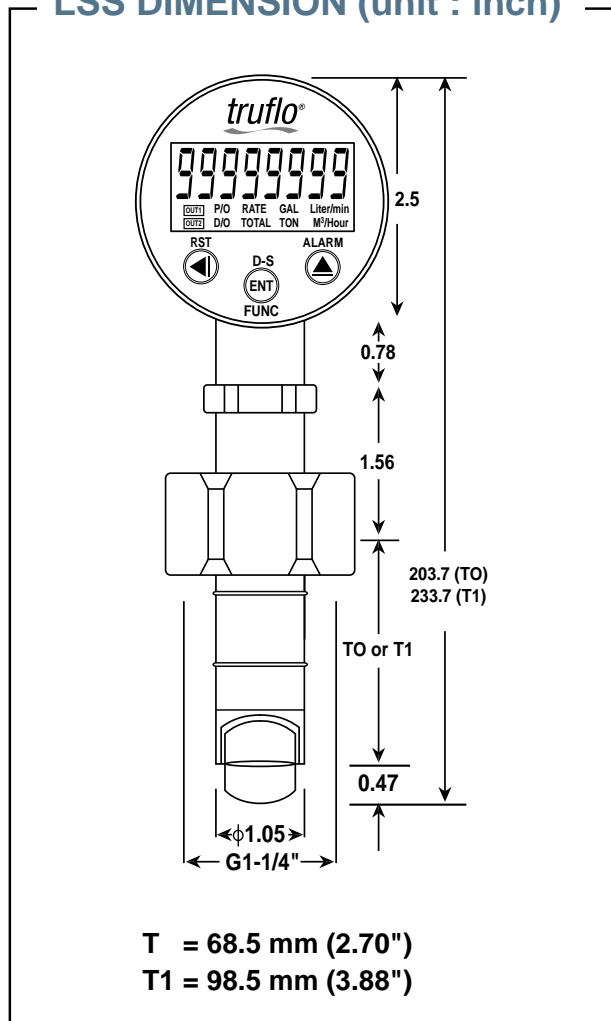

LS DIMENSION (unit : inch)

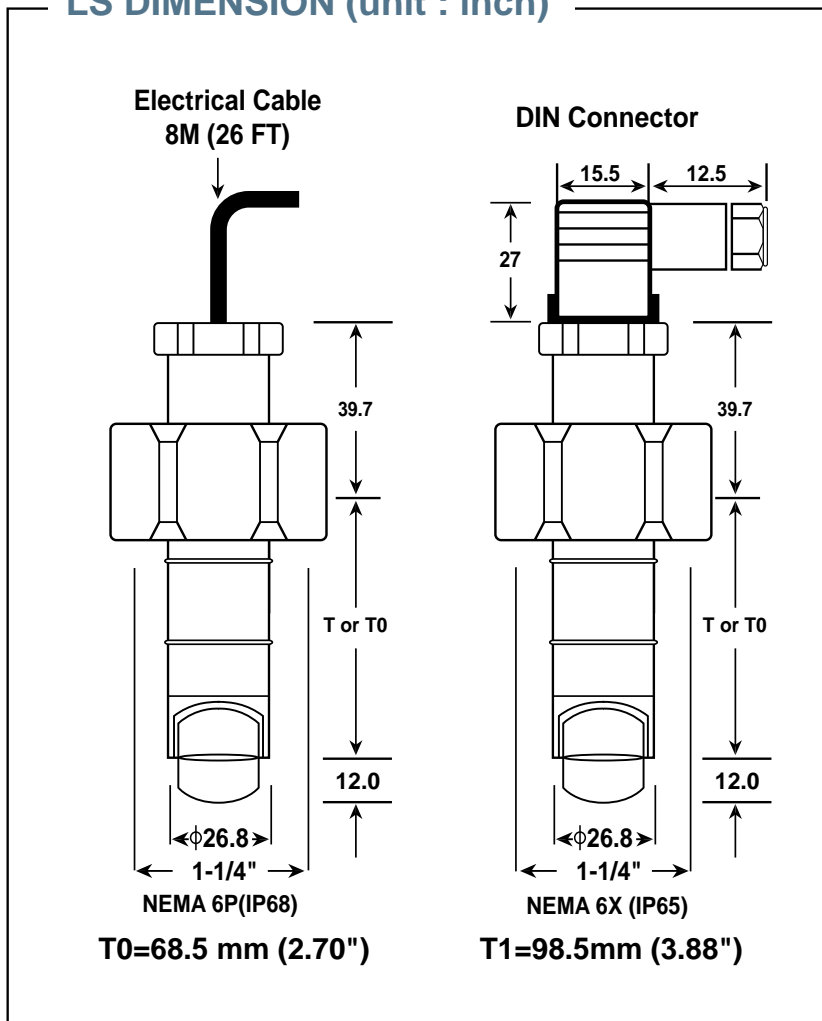

Warranty Information

All warranty and non-warranty repairs being returned must include a fully completed Service Form and goods must be returned to Truflo directly or to the distributor. Product returned without a Service Form will not be warranty replaced or repaired.

Truflo Sensors are warranted out of box but not against any damage, due to Process or Misapplication failures (e.g. High Temperature, Chemical Attack Due to Misapplication) or Physical mishandling of product.

Safety Information

1. Depressurize and vent system prior to installation or removal.
2. Confirm chemical compatibility before use.
3. DO NOT exceed maximum temperature or pressure specs.
4. ALWAYS wear safety goggles or faceshield during installation and/or service.
5. DO NOT alter product construction.



Warning / Caution / Danger

Indicates a potential hazard. Failure to follow all warnings may lead to equipment damage, injury, or death



Hand Tighten Only

Overtightening may permanently damage product threads and lead to failure of the retaining nut.



Note / Technical Notes

Highlights additional information or detailed procedure.



Do Not Use Tools

Use of tool(s) may damage product beyond repair and potentially void product warranty.



WARNING!



Personal Protective Equipment (PPE)

Always utilize the most appropriate PPE during installation and service of Signet products.

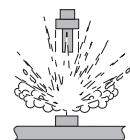

Pressurized System Warning

Sensor may be under pressure, take caution to vent system prior to installation or removal. Failure to do so may result in equipment damage and/or serious injury.

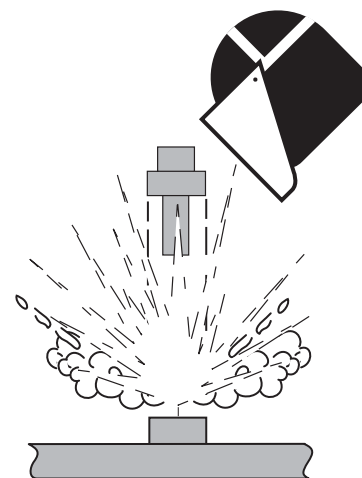

(Max Fluid Velocity should NOT EXCEED 8 ft/sec)

DC Power Only